

RETAINING WALLS - PLAN SUBMITTAL CHECKLIST

Purpose

This handout summarizes the requirements for a complete plan review submittal for retaining wall construction located within a residential lot.

City of Dublin's Municipal Code Section 7.28.290, Exceptions, outlines when retaining walls are exempted from permits.

Permits Required

- Retaining walls exceeding 3-ft. in height, measured from the top of footing to the top of wall, unless supporting a surcharge or ground slope exceeding 1:20 (5%) slope or impounding Class I, II, or IIIA liquids.

Surcharge: A condition that results in additional pressure that is exerted on a cut or retaining wall (e.g., sloping soils, groundwater, adjacent structures, stored materials, within 5-ft of the back of the wall).

If the work involves additional work such as the installation of new landscape irrigation sprinklers, exterior cook areas and elevated decks, fire pits, etc., separate electrical, plumbing and mechanical permits will be required. Please consult with Building Staff on the types of permits required for additional accessory elements not mentioned in this handout.

Additional Approvals

Planning

Retaining wall heights are regulated by the zoning regulations. Contact the Planning Division at **(925) 833-6610** for the suitability of the work.

Public Works

Drainage, easement locations, and encroachment permits are reviewed by the Public Works Department. It is highly suggested that approval be obtained prior to the submittal of plans to verify if the site is on a geogrid system; additional information may be necessary from a geotechnical engineer. Contact Public Works at **(925) 833-6630** for more information.

Geogrid: Geosynthetic material used to reinforce soils and similar materials commonly used to reinforce retaining walls, subbases or subsoils.

Dublin San Ramon Services District (DSRSD)

Approval must be attained from **DSRSD** prior to issuance of the City Master Plan Checks Only. To apply, visit:

https://selfservice.dsrdsd.com/EnerGov_Prod/SelfService#/home. If this is the first time visiting the site, you will need to sign up for an account. You can find the instructions here: <https://www.dsrdsd.com/do-business-with-us/planning-and-permitting> under DSRSD Requirements "How to register" and "How to apply for review". Please contact DSRSD directly for additional information and questions by email at plansubmittals@dsrdsd.com or by phone at **(925) 828-0515**.

Plan Submittal for Construction

- To submit for a permit the following information must be completed electronically through <https://dublin.ca.eprocess360.com>.
 - Please request via permits@dublin.ca.gov a copy of the instructions to submit and upload your plan submittal.
 - A completed permit application worksheet. [Permit Application Form](#)
 - Contractor's City of Dublin Business License must be current.
- Architectural and structural plans supporting the proposed design.
- Structural calculations sets stamped and signed by the licensed professional (as applicable).
- Complete Special Inspection & Testing Agreement form completed and wet-signed by all parties (as applicable).
- Completed permit application.
- Plan check fee payment.

Minimum Plan Requirements

Site Plan

- Location of retaining wall(s) or any other accessory structures on the property.
Note: All parts of the wall, including the footing, must be located on private property owned by the individual listed as the property owner on the permit application.
- Dimensions of the wall, length, and height (measured from the top of the footing to the top of the wall).
- Distance from the wall footing to all adjacent structures, embankments, and property lines.
- Show existing slope and proposed grading.
- Provide top-of-wall and bottom-of-wall elevations at various points of the length of the wall.
- Show existing yard drain locations and proposed wall sub-drain connections discharging onto the on-site storm drainage pipe network.
- If designing exterior elements - stairs, guards, landscaped areas - provide details for rise and run width, handrails, guards, connection hardware, and material specifications.

check process is ten business days for the initial and all subsequent resubmittals.

Retaining Wall Detail

- Provide a section view on plans to scale showing the slope, the retaining wall location, depth of the footing, and the wall height.
- Mitigating method for removal of existing geogrid (if applicable).
- Specifications for soil design criteria; materials for masonry, concrete, grout, reinforcing steel.
- Provide a listing agency report (when applicable).
- Specify if special inspection will be required.

Plan Check Time

Permits may be issued the same day for specific areas in the City provided clearance is initially obtained from other departments and it meets certain conditions:

- Complete information is presented;
- **The illustration shown in this handout is used;**
- The project location does not have a geogrid system; and
- The wall is designed for a maximum of 4-ft in height.

The wall sample illustrated on page three is designed to retain only sloping backfill. No building foundation, retaining wall, driveway, parking, fence, or other potential source of loading on the upper level is allowed within 45 degrees to the height of the wall.

Retaining walls greater than 4-ft shall require an engineered design and complete submittal. The plan

Permit Issuance

One set of approved plans will be returned to the applicant to be maintained at the job site until the final inspection has been made. The Building Division will keep a second set on file until 90 days after construction has been completed. The third set will be forwarded to the County's Assessor's Office.

Questions

Contact the **Building Division** at **(925) 833-6620** for inquiries on permit and plan check fees. Project information such as valuation cost, length and height of retaining walls is necessary to provide estimates on fees.

4-ft High CMU Retaining Wall (Concrete Masonry Unit)

SPECIFICATIONS

1. Concrete Masonry Unit (CMU) = 8-in height x 8-in depth x 16-in width
2. Compressive strength of concrete masonry = 1500 psi
3. Concrete masonry unit shall conform to ASTM C55 or ASTM C90
4. Soil bearing pressure = 1500 psf
5. Lateral sliding pressure = 100 pcf
6. Grout strength = 2000 psi @ 28 days and shall conform to ASTM C476
7. Concrete compressive strength = 2500 psi at 28 days
8. Thickness of bed joints shall not exceed 5/8-in
9. Reinforcing steel shall be Grade 40 for #4 bar (1/2-in or 13 mm) or #5 bar (5/8-in or 15 mm) conforming to ASTM A706
10. Footing shall be poured on undisturbed natural soil or on compacted fill with a minimum compaction of 90%
11. Reinforcement steel shall be accurately placed and adequately supported before concrete or grout is placed
12. Weep holes provided in the masonry wall shall be 1/2-in diameter at maximum spacing of 32-in on center (o.c.), sloped to drain, located at 3-in above ground level finish grade
13. Masonry wall control joint shall be located at 40 feet or less on center
14. Reinforcing steel shall be overlapped 40 bar diameter (20-in for 1/2-in bar or 25-in for 5/8-in bar) for rebar Grade 40
15. Fill all CMU voids with grout
16. Grout pours greater than 12 inches must be consolidated by mechanical means

Maximum slope of soil behind top of wall = one to four (1:4)

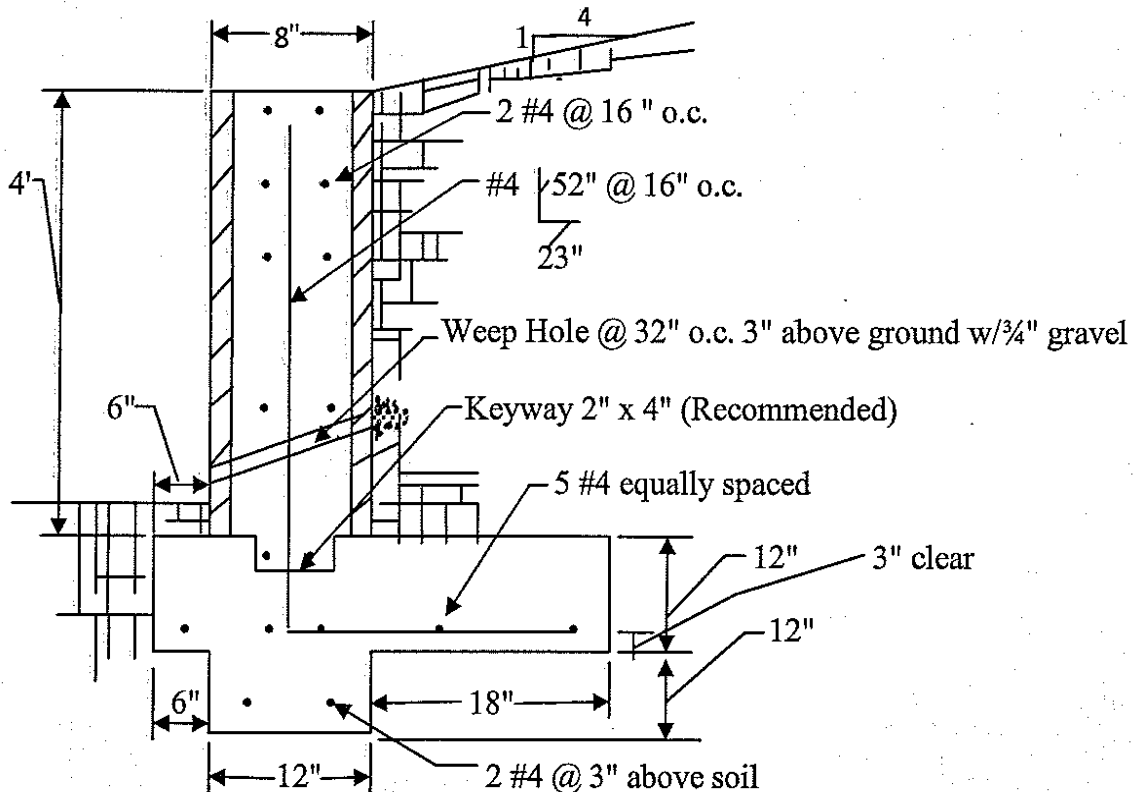

SAMPLE ONLY

The information provided in this handout is for general purposes and is intended as a guideline only. Additional requirements may be enforced as deemed appropriate.